



ExtensoJet Burners

Model EJ075

Version 2

Main Specifications

PARAMETER	SPECIFICATION		
	Nat. Gas	Propane	Butane
Maximum input Btu/hr (kW)	750,000 (220)	750,000 (220)	750,000 (220)
Minimum Input, on-ratio Btu/hr (kW)	75,000 (22)	75,000 (22)	75,000 (22)
Gas Inlet Pressure "w.c. (mbar) • Fuel pressure at gas inlet (P _{gas} – see page 2)	18.6 (46.3)	15.1 (37.6)	13.9 (34.6)
Air Inlet Pressure "w.c. (mbar) • Air pressure at air inlet (P _{air} – see page 2)	17.7 (44.0)	16.1 (40.1)	15.6 (38.8)
High Fire Flame Length Inches (mm)	27(686)	18 (457)	17 (432)
Maximum flame velocity ft/s (m/s) • 15% excess air, at maximum input	460 (140)		
Flame detection	Flame rod only		
Maximum Furnace Temperature °F (°C)	2250 (1232)		
Approximate Weight Lbs. (kg)	40 (18)		
Fuel	Natural Gas, Propane, Butane <i>For any other mixed gas, contact Eclipse for orifice sizing.</i>		

- All information is based on laboratory testing in neutral (0.0" w.c.) pressure chamber. Different chamber size and conditions may affect the data.
- All inputs based upon gross caloric values.
- Eclipse reserves the right to change the construction and/or configuration of our products at any time without being obliged to adjust earlier supplies accordingly.

Specifications

Adjusting Diagram

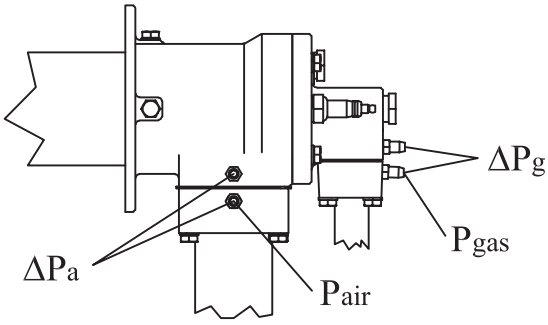

NO_x Emissions
Stoichiometrically fired and corrected to 3% O₂

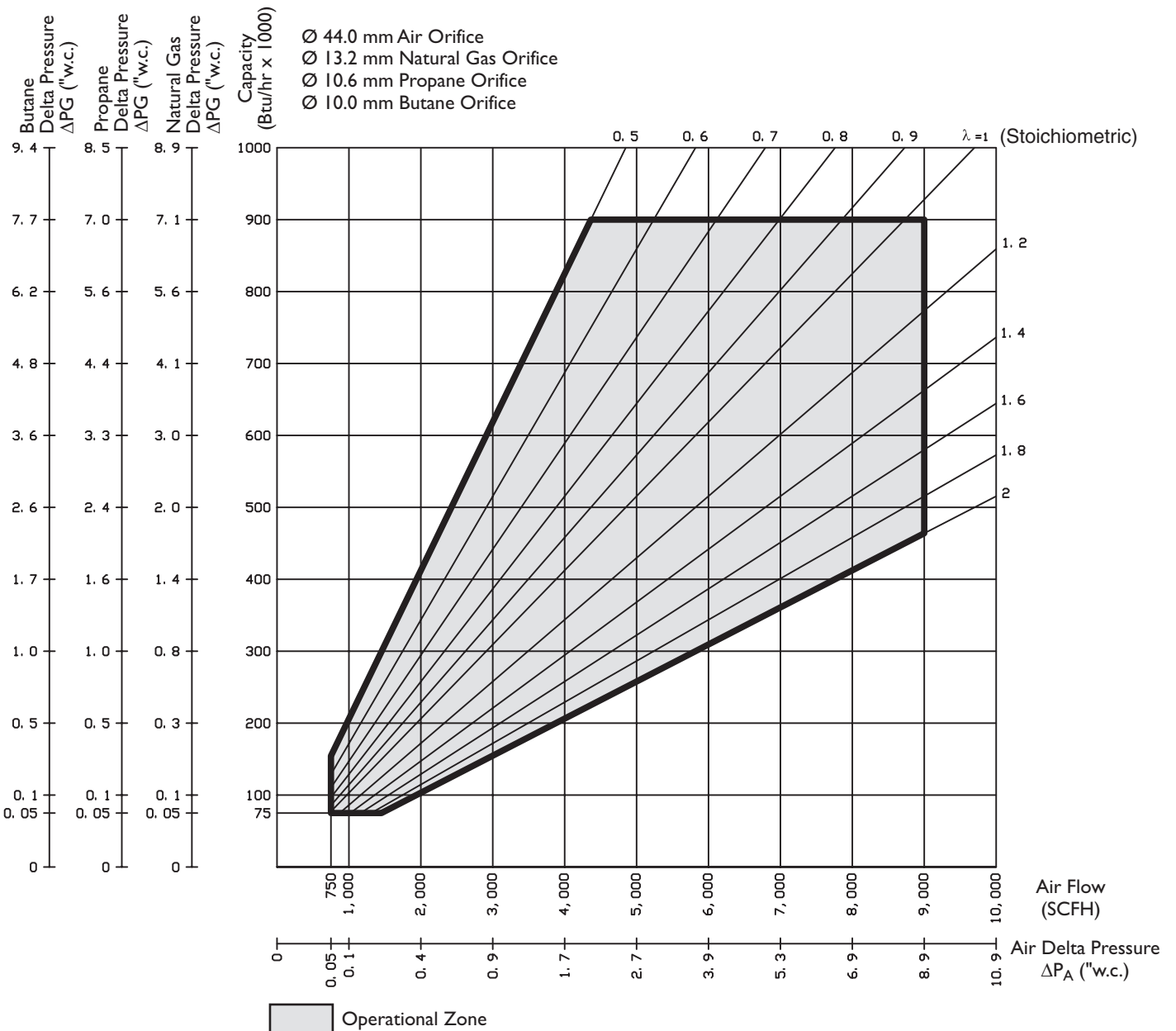
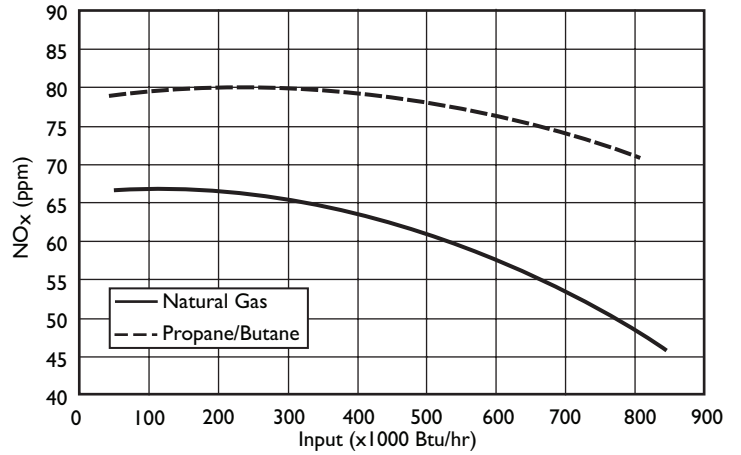

**Dimensions
mm(inches)**

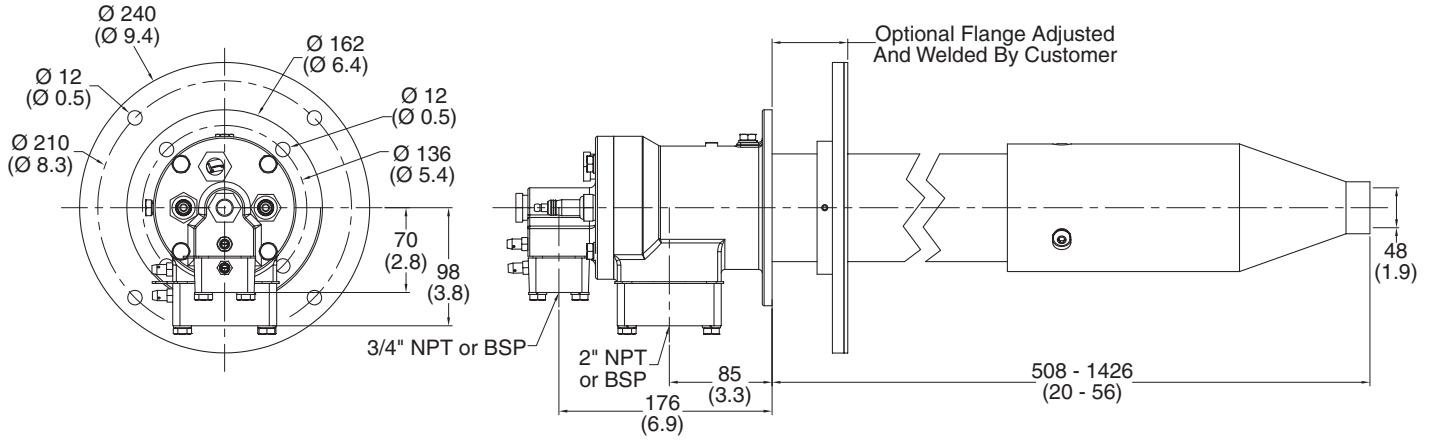



Offered By:

Power Equipment Company
2011 Williamsburg Road
Richmond, Virginia 23231
Phone (804) 236-3800
Fax (804) 236-3882

www.peconet.com